

STIGA VILLA

85 M

8211-3013-10

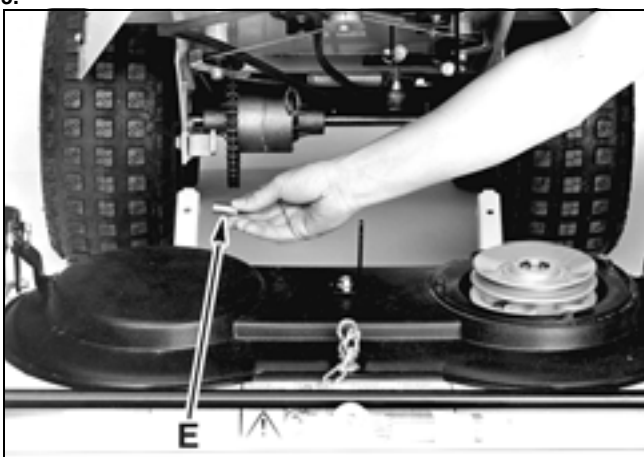

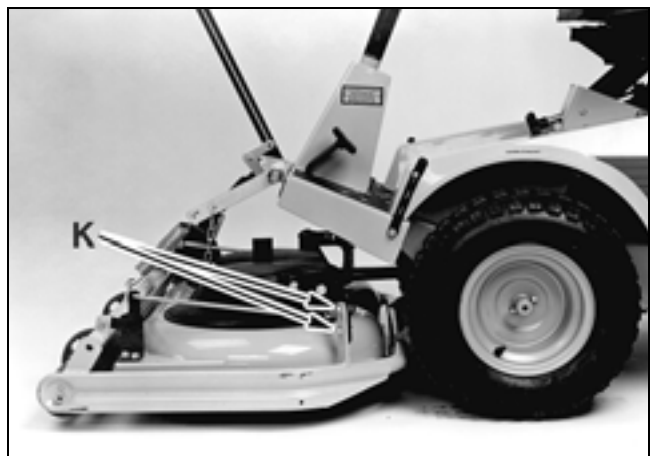
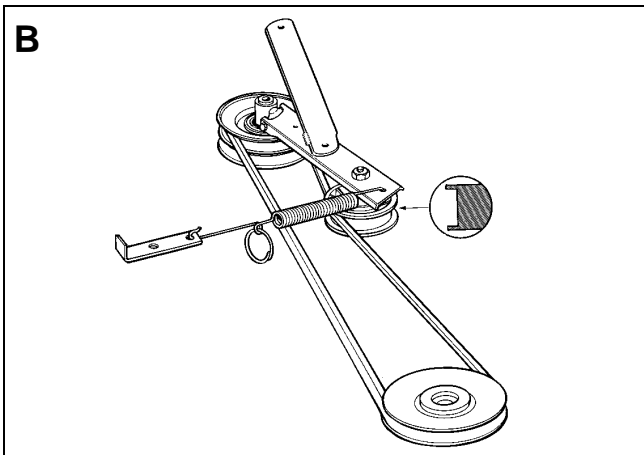
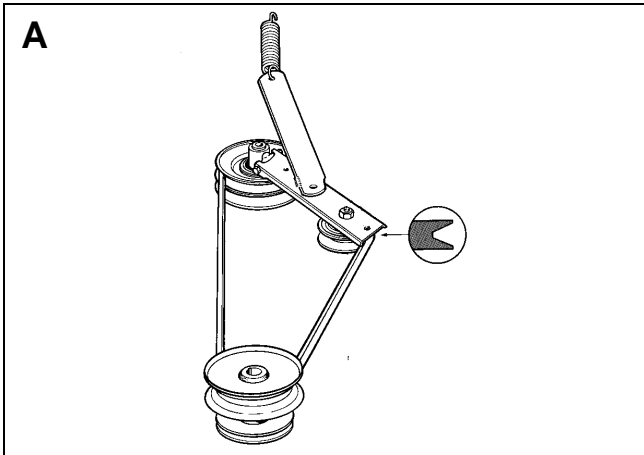

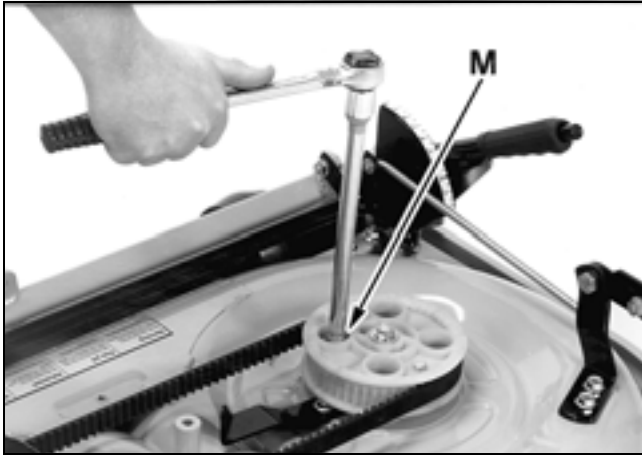

9.

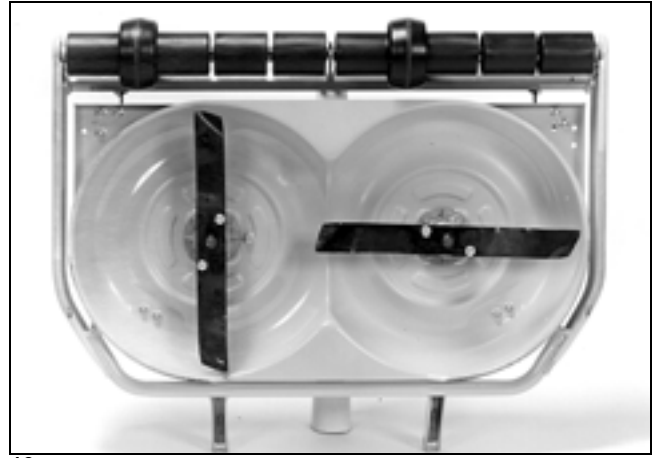

10.

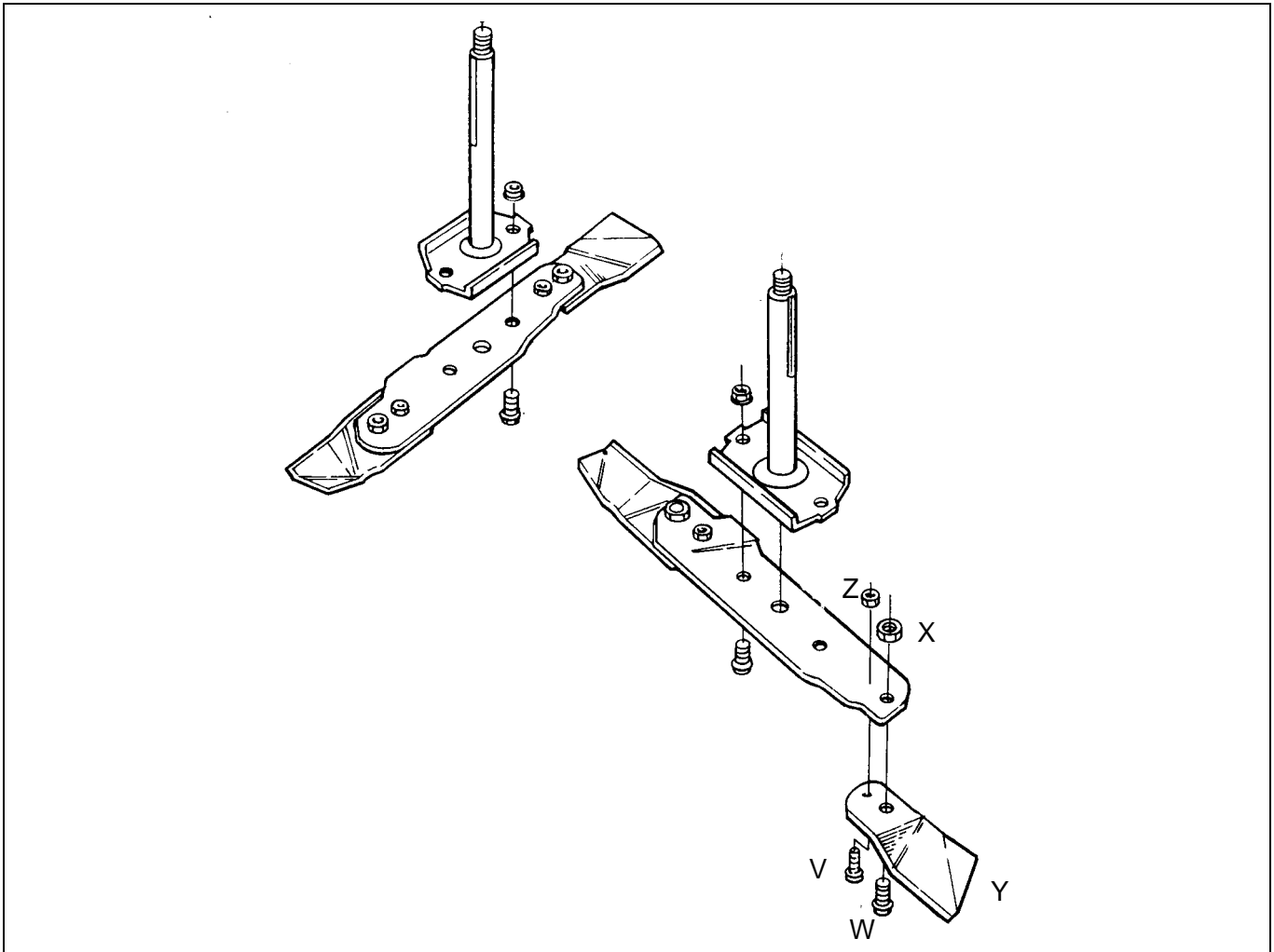

11.

Denna produkt, eller delar därav, omfattas av följande
 mönsterskydd:
 This product, or part of it, is covered by the following
 design registration:

Sverige/Sweden 62 435

SYMBOLS

The following symbols are displayed on the machine in order to remind you about the safety precautions and attention necessary when using the machine.

The symbols mean:



Warning!

Read the instruction book and safety manual before using the machine.



Warning!

Do not put hands or feet under the cover of the machine when it is running.



Warning!

Beware of objects being flung out. Keep spectators away.



Warning!

Before starting any repair work, remove the spark plug cable from the spark plug.



INTRODUCTION

The power outlet's tension roller and tension arm's spring on the base machine are available in two versions (figs 1 and 2).

NOTE! To be able to fit this mower deck ("Multi-clip" mod. 85M) version B is required.

VERSION A:
(Standard on models made between 1982 - 83).

If the base machine is fitted with version A a separate assembly set is required to be able to fit the mower deck.

Assembly set, art. No.: 13-1967-11.

The set contains a v-belt, tension roller, spring, assembly components and assembly instructions.

N.B. Older base machines can, however, be fitted with version B if they have previously been adapted for use with a "Multiclip" mower deck.

VERSION B:
(Standard on machines made from 1994 -).

The mower deck can be fitted directly.

ASSEMBLY

MOWER DECK

1. Remove both mounting bolts D on the base machine (fig 3).
2. Insert both spacer sleeves E in the mower deck's arms (fig 4). The spacer sleeves are supplied in a plastic bag.
3. Bolt the mower deck to the base machine.
4. Pull the v-belt onto the mower deck's pulley. (This is carried out easier if the height adjustment lever is in position "5").
5. Make sure that the tension roller J is on the *outside* of the v-belt (figs 2 and 5).
6. Hook the spring into the bracket G (figs 2 and 5).
7. Screw the guard H in position using three screws (fig 6). The screws are supplied in the plastic bag.
8. Hook the chain I and lifting spring F in the attachment's lift arm (fig 6).

SETTING

For the mower deck to mow evenly and cleanly it needs to be adjusted correctly:

1. Make sure the tyre pressure is correct:
Front: 0.4 bar (6 psi).
Rear: 1.2 bar (17 psi).
2. Place the machine on a flat surface. Loosen the screws K (fig 7).
3. Adjust the mower deck so that the casing's front and rear edges are the same height from the floor.
4. Tighten the screws.

USE

MOWING HEIGHT

The mower deck has 17 fixed mowing heights, from 30 mm to 80 mm.

N.B. The stated mowing heights apply when the machine is standing on firm ground.

MOWING ADVICE

For the best "Multiclip" effect follow this advice:

- mow regularly.
- use full throttle on the engine.

- keep the underside of the mower deck clean.
- use sharp blades.
- do not mow wet grass.
- mow twice (using different mowing heights) if the grass is long.

MAINTENANCE



No service action must be taken on the mower deck unless:

- the engine has been stopped.
- the ignition key has been removed.
- the spark plug cap has been removed from the spark plug.
- the parking brake is engaged.
- the mower deck is disengaged.

CLEANING

After use, rinse off the underside of the mower deck using a garden hose.

If grass cuttings have dried on to the attachment, dismantle the mower deck and scrape clean the underside.

If necessary touch-up the underside using a suitable paint to prevent corrosion.

CHANGING THE DRIVE BELT

1. Remove the mower deck from the base machine.
2. Remove the transmission casing.
3. Loosen the tension arm L (fig 8).
4. Loosen the right hand bearing box's fixing bolts M (fig 9).
5. Fit the new drive belt.



The new drive belt must be fitted so that the blades are square (90°) to each other. See figure 10. If you fit the drive belt incorrectly the blades will hit each other resulting in the blades being damaged.

6. The belt is tensioned by pushing the tension arm L forwards and then securing in position.

7. Tighten the bearing box's fixing bolts M.



When the drive belt is fitted, check, by turning the mower deck over and turning the blades, that it has been fitted correctly. NOTE! The mower deck should be dismantled from the base ma-

chine.

8. Now refit the mower deck on the base machine.

CHANGING BLADES



Use protective gloves to prevent cuts when changing blades/blade tips.

Make sure the blades are always sharp. This gives the best mowing results.

Always check the blade(s) after an impact. If the blade system has been damaged the defective parts must be changed.



Always use original spare parts. Using non-original spare parts can result in the risk of damage even if they fit in the machine.

The cutting system consists of two blade bars, each with two interchangeable blade tips Y (fig 11). Both blade tips should be replaced at the same time to avoid any imbalance.

Fit the new blade tips. Tighten the screws V and W fully. Tightening torque: V - 9.8 Nm, W - 24 Nm.

And heavy impact can result in the blade tip being folded aside. Loosen the locking nut X and turn the blade tip back to its correct position. Mount a new shear bolt V. Tighten the lock nuts X and Z.

SPARE PARTS

STIGA original spare parts and accessories are constructed exclusively for STIGA machines. Note that non original spare parts and accessories have not been checked or approved by STIGA.



Usage of such parts and accessories can influence the machines operability and safety. STIGA cannot be held responsible for injuries caused by these products.

STIGA reserves the right to make changes in the product without prior notice.